



DOSING AND MIXING

MINICOLOR GRAVICOLOR

Simple Solutions



ZERO LOSS

SIMPLE SOLUTIONS

EASILY REALISED, COMBINED AND INTEGRATED

Simple solutions comprise a range of equipment for optimising and automating plastics processing machinery production. All units can be combined or expanded in order to satisfy increasing and changing requirements. They help the plastics processor to equip their individual machines or production cells. In the case of injection moulding, extrusion or blow moulding machines, cost savings can be easily achieved with minimum outlay.

Individual applications and problems are rapidly solved and may be the first steps towards a later system solution. The simple solutions range correspond to motan's high quality standards in spite of lower prices and are available through motan's world-wide sales and service network. All units may of course be integrated into system solutions.

PRODUCT RANGE

- Material bins for clean and well arranged material storage
- Dryers for energy-saving material drying to a defined residual moisture, or removing surface moisture and preheating of material
- Conveying equipment for automatic material transport and supply to the machine
- Dosing and mixing units for self-colouring or for the addition of additives and regrind

EXAMPLES FOR STEP-BY-STEP AUTOMATION OF INJECTION MOULDING MACHINES

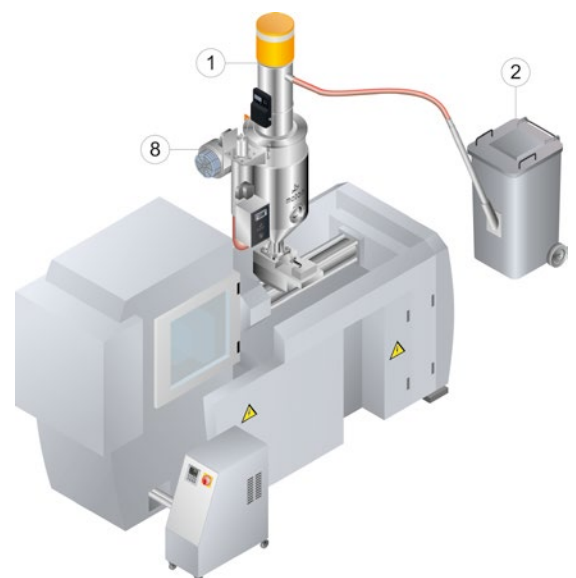
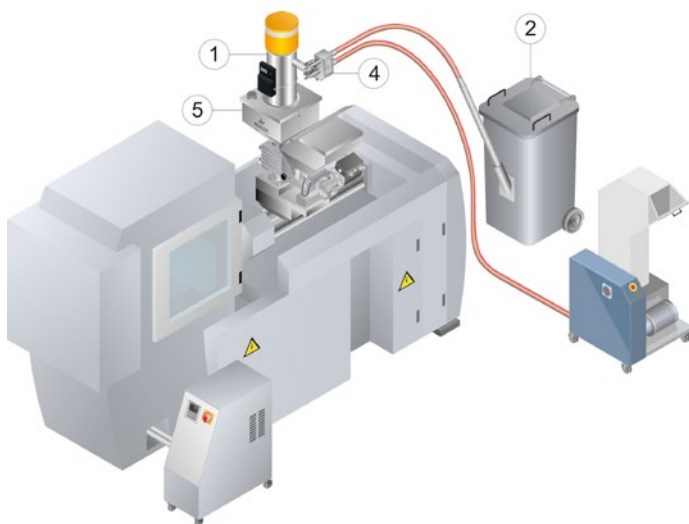

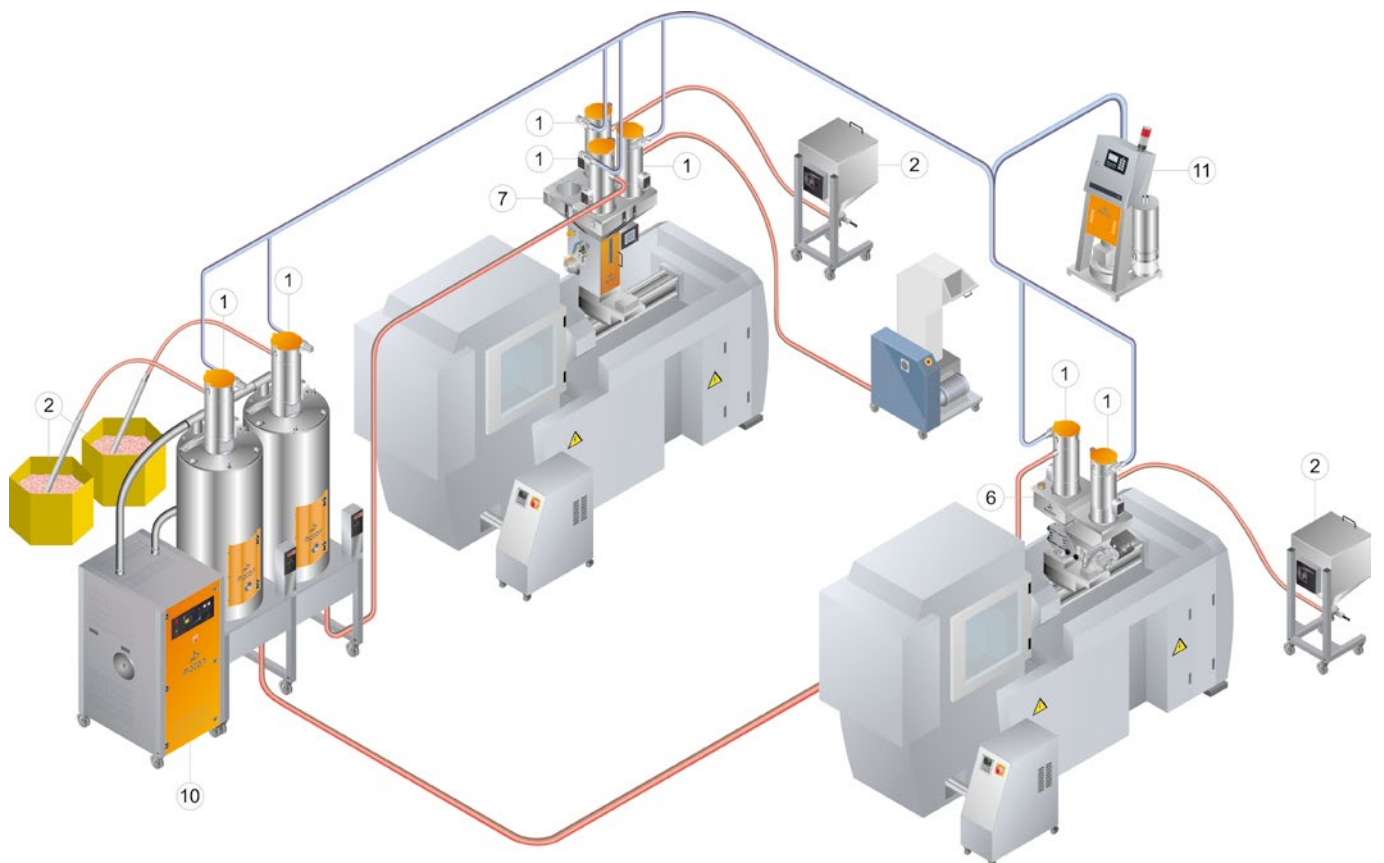
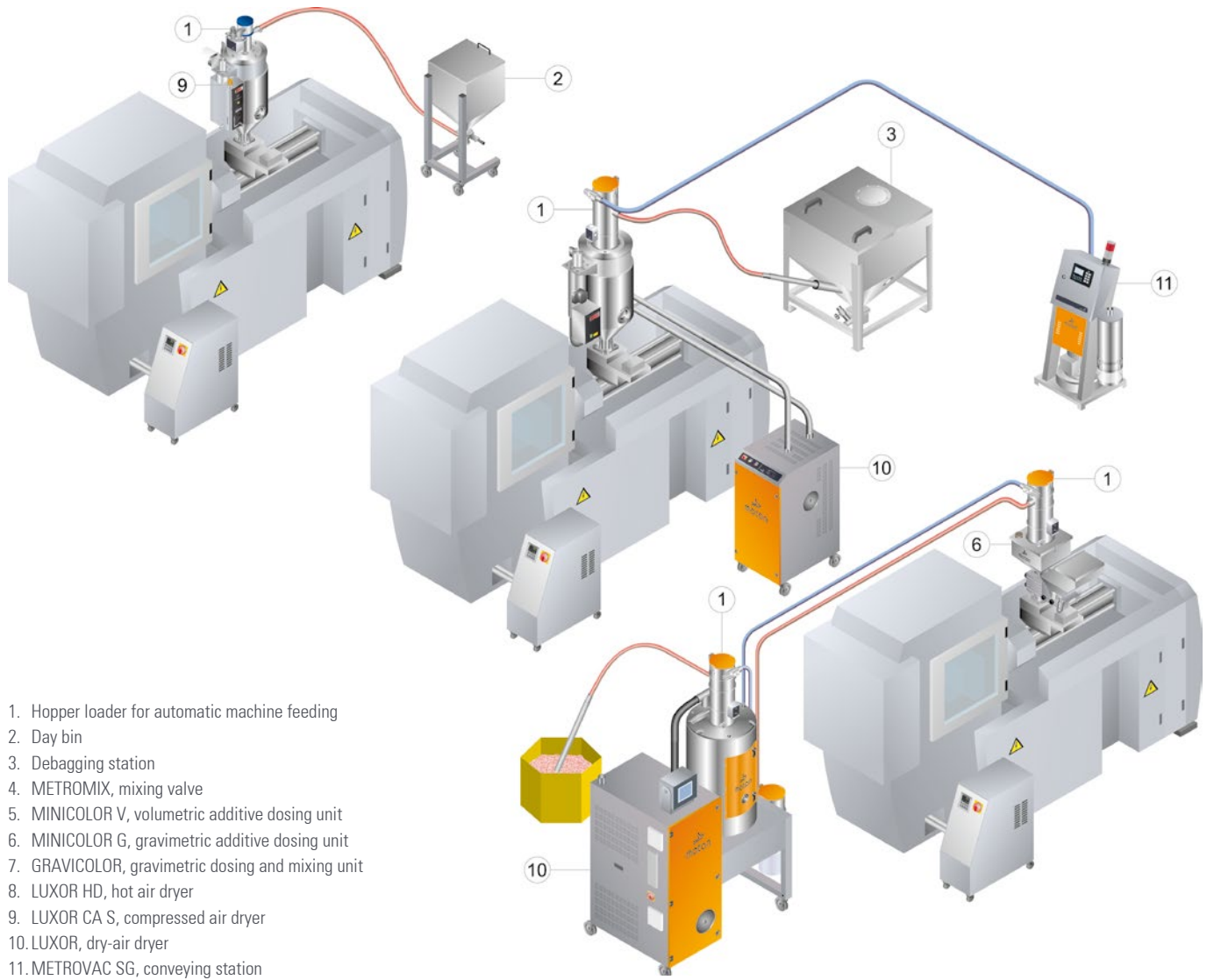

MINICOLOR V

VOLUMETRIC ADDITIVE DOSING UNITS

MINICOLOR V with screw dosing



MINICOLOR V with disc dosing



The demand for an excellent mixing quality and consistently accurate dosing is a must when combining additives with the virgin material at the processing machine.

The volumetric dosing and mixing unit MINICOLOR V meets and exceeds these requirements. Mounted between the machine hopper and the feed throat of the plastics processing machine, it requires very little space.

A stainless steel cruciform in the mixing neck divides the free-flowing main component into two streams of material. They flow together with the simultaneously dosed additives at the feed inlet producing a homogeneous mixture.

Depending on need and requirement, screw or disc dosing units can be installed at the mixing neck. Disc dosing is ideal for translucent and opaque parts as well as for dosing very small quantities.

The additive supply hopper can be filled easily by hand or with a METRO VL Venturi material loader.

General view of all dosing and mixing units						
Dosing and mixing unit	Additive/Masterbatch dosing unit			Dosing/Mixing unit		
	MINICOLOR V	MINICOLOR G	GRAVICOLOR 30 MD	GRAVICOLOR 60	GRAVICOLOR 100	
Dosing process	synchronous	synchronous	batch	batch	batch	
Dosing system	volumetric	gravimetric (loss-in-weight)	gravimetric (gain-in-weight)	gravimetric (gain-in-weight)	gravimetric (gain-in-weight)	
Number of possible dosing modules (main component/subsidiary component)	- / 1 - / 2	- / 2	2 / 2	2 / 2	2 / 2	
Dosing range main component (%)	free-flowing	free-flowing	1 - 100	1 - 100	1 - 100	
Dosing range subsidiary component (%)			0.1 - 10	0.5 - 10	0.3 - 10	
* Total dosing throughput [kg/h]			60	90	150	
** Dosing range additive with dosing screw G1 - G3 (kg/h)	0.13 - 49.2	0.13 - 49.2				
** Dosing range additive with dosing disc DD1 - DT6 (kg/h)	0.05 - 458.38					
Control	VOLU MC VOLUnet MC	GRAVInet MC	GRAVInet GC	GRAVInet GC	GRAVInet GC	
Timer function	•	•	•	•	•	
Manual calibration	•	•				
Automatic calibration		•	•	•	•	
Regrind compensation function		•	•	•	•	
Operation: 7-segment display / plastic film keypad	•					
Operation: Graphic user interface / touch panel		•	•	•	•	
Extruder tachometer signal processing		•	•	•	•	
Recipe management		•	•	•	•	
Process documentation (throughput acquisition, etc.)		•	•	•	•	
Can be networked (Ethernet)		•	•	•	•	
Additives and main components are dosed			•	•	•	
IntelliBlend for highest dosing and mixing accuracy			•	•	•	
Micro dosing for minimum quantities			•			
Most cost effective solution for colouring of masterbatch	•					
Most cost effective solution for weighing all components			•	•	•	

* Dosing throughput related to a bulk weight of 0.6 kg/dm³

** Dosing range related to a bulk weight of 0.8 kg/dm³

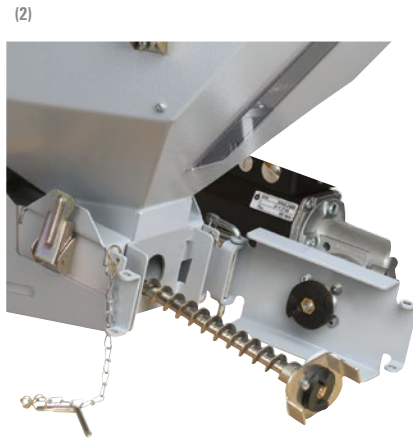
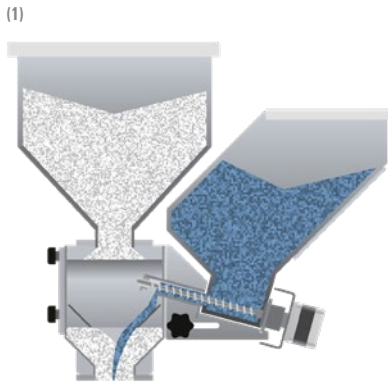

MINICOLOR - dosing process

With the MINICOLOR, up to two additives in granular form can be simultaneously dosed into the free-flowing volume flow of the main material. During screwback with an injection moulding machine, dosing occurs simultaneously or continuously with the screw speed of the extruder.

Mixing neck (Fig. 1)

The stainless steel mixing cruciform separates the main material flow. The additive (1 or 2) is centrally dosed via screw or disc dosing. Subsequently, the components flow together ensuring a homogeneous mixing.

Screw dosing (Fig. 2)

The dosing motor is swivel-mounted. There are three different sizes of wear-resistant dosing screws available, and they can be removed without the use of tools. During calibration, the dosing module can be withdrawn in order to collect and weigh the additive sample. The additive supply hopper can be changed quickly.

Disc dosing (Fig. 3)

The dosing disc enables real volume dosing guaranteeing a very high dosing accuracy – even for very small dosing quantities. The discs are available in nine different sizes (wear-resistant design optional).

During calibration, the dosing head can be withdrawn in order to collect and weigh the additive sample. The dosing module can be changed quickly.

Controls

There are two types of controls available, and dosing can be either continuous for extrusion applications or during screwback for injection moulding machines. In conjunction with the brushless motor and control, the MINICOLOR V offers one of the most consistent and repeatable dosing rates on the market today.

VOLU MC control (Fig. 4)

Modern microprocessor control with time function and easy operation for a MINICOLOR with one dosing module.

VOLU net MC control (Fig. 5)

- Image-guided operator interface on colour graphic display with touch screen for simple operation
- Up to 50 recipes can be stored
- Reporting function via Ethernet
- Suitable for one or two dosing modules
- Standard network interface (Ethernet)
- The control can be integrated in the motan CONTROLnet network
- Regrind compensation function

MINICOLOR G

GRAVIMETRIC ADDITIVE DOSING UNITS

MINICOLOR G with one dosing module



Detail of load cell

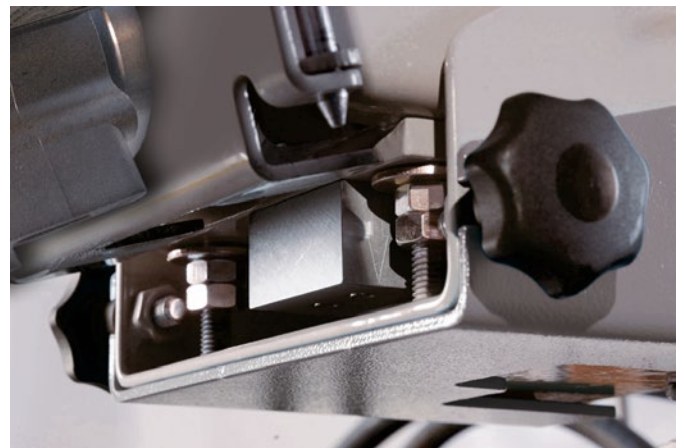

MINICOLOR G

Compact gravimetric dosing and mixing unit for one main component and one masterbatch or additive in granular form suitable for injection moulding machines, extruders and blow moulding machines. With the GRAVInet MC control, up to two screw dosing modules can be operated.

The unit is based on the well-tried MINICOLOR concept with a gravity mixing funnel guaranteeing a homogeneous material mix and eliminating separation.

The dosing module for masterbatch or additive sits on a robust, but extremely precise, load cell and operates using loss-in-weight metering technology.

GRAVInet MC control

- Separate control with 5 m connection cable to the MINICOLOR G mixing unit. Thus no thermal influence. User-friendly location possible
- Easy handling through colour graphic display with touch screen and image-guided operator interface
- Potential-free alarm output and external signal input (external contact) for the dosing cycle
- Storage of up to 50 recipes possible
- Detailed report function via Ethernet
- Automatic adjustment of the masterbatch dosing depending on the regrind percentage
- Unit with two dosing modules enables fast colour changes
- Standard network interface (Ethernet)
- The control can be integrated in the motan CONTROLnet through a common operating platform with centrally operating and monitoring possibilities.

MINICOLOR G with two dosing modules



MINICOLOR G enables easy addition of regrind. Due to automatic calibration, the commissioning time is extremely short. The unit is insensitive to vibrations and is specially designed for mounting directly onto the feed throat of the processing machine.

The metering supply hoppers can easily be filled manually or automatically with a hopper loader or a Venturi material loader (METRO VL G).

METRO VL
METRO VL G



METRO VL / METRO VL G

For automatic filling of the metering supply hopper of the MINICOLOR V and MINICOLOR G, a Venturi loader can be used. The loader can be installed by replacing the supply hopper lid.

With METRO VL, a level sensor in the hopper signals the need for material and ensures that the hopper never runs empty.

With METRO VL G, this is done using a load cell.

MINICOLOR V/MINICOLOR G

TECHNICAL DATA

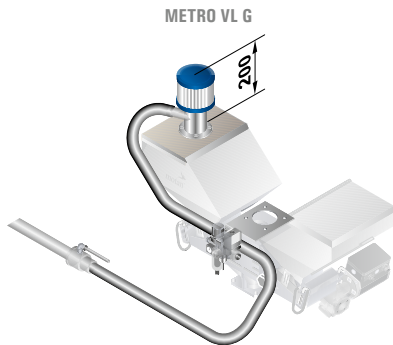
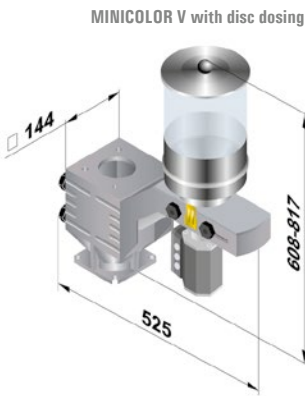
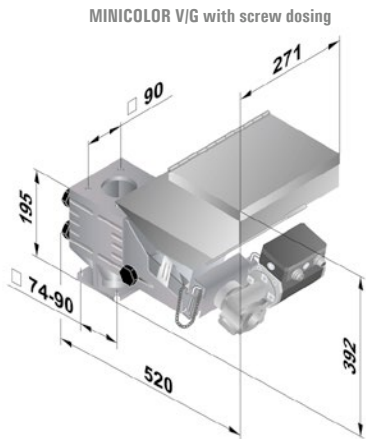

All dimensions in mm

Technical data		
Mixing unit Type MINICOLOR	MINICOLOR V	MINICOLOR G
Dosing type	volumetric	gravimetric
Number of dosing modules	1 or 2	1 or 2
Dosing capacity (screw dosing) (kg/h)*	G1S 0.13 - 4.7 G2S 0.34 - 26.6 G3S 0.7 - 49.2	0.13 - 4.7 0.34 - 26.6 0.7 - 49.2
Dosing capacity (disc dosing) (kg/h)*	DD1 0.05 - 2.56 DD2 0.11 - 5.62 DD3 0.19 - 9.71 DT1 0.59 - 29.26 DT2 1.73 - 86.56 DT3 1.95 - 97.46 DT4 5.77 - 288.32 DT5 3.10 - 154.94 DT6 9.17 - 458.38	
Volume of supply hopper (screw dosing) (l)	12	12
Volume of supply hopper (disc dosing) (l)		
Manual filling (glass) (l)	6 / 10.5	
Filling through hopper loader (glass/stainless steel) (l)	6 / 7.5	
Power supply (V/Hz)	1/N/PE 230/50	1/N/PE 230/50
Connected load (W)*	150	150
Control	VOLU MC** or VOLUnet MC	GRAVInet MC
External contact	potential-free	potential-free
Weight approx. (kg)	15 (without control)	16 (without control)
Colour RAL (orange/grey)	2011/7040	2011/7040

* Varies with bulk density. Indicated values for masterbatch: bulk density = 0.8 kg/dm³
** VOLU MC max. 1 dosing head

Technical data		
Hopper loader Type* ...	METRO VL G	METRO VL
Conveying capacity (kg/h)**	max. 30	max. 30
Mode of conveying	compressed air	compressed air
Compressed air oil and water-free (bar)	3 - 7	3 - 7
Air consumption at 3 bar (m ³)	0.12	0.12
Power supply (V/Hz)	230/50	230/50
Weight approx. (kg)	2.5	2.5
Colour (RAL)	stainless steel, electropolished	

* The following items are included with delivery: 3 m material hose and a suction pipe
** The conveying capacity refers to a conveying distance of 5 m at a height of 3 m. The information refers to materials with a bulk density of 0.6 kg/dm³

Subject to technical changes

YOUR BENEFITS

MINICOLOR V and G

- Screw and disc dosing (volumetric)
- Wear-resistant dosing screws/dosing discs
- Fast and easy to clean
- Password protected recipe management (not with VOLU MC)
- Very high dosing accuracy, even with very small quantities (disc dosing unit)

Cost savings through

- no warehousing of precoloured material
- fast material changes for masterbatch

- minimal additive usage
- maintenance-free dosing motor
- automatic regrind compensation

Production reliability through

- inclined dosing screw (no material trickle)
- real volumetric dosing with disc dosing

Additional benefits with MINICOLOR G

- Very high dosing reliability through loss-in-weight technology
- Recipe management
- Acquisition of throughput rates
- Possibility of centralised acquisition of throughput rates via Ethernet as a standard
- Simple operation

Cost savings through

- automatic calibration
- automatic monitoring of the dosing throughput and adjustment to changing bulk densities

GRAVICOLOR

GRAVIMETRIC DOSING AND MIXING UNITS

Cone-dosing

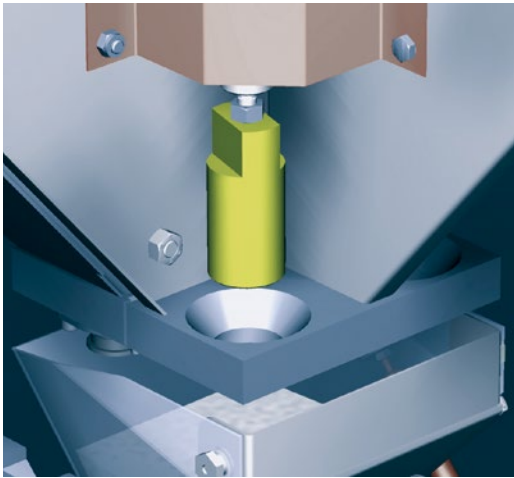

Micro-dosing GRAVICOLOR 30 MD

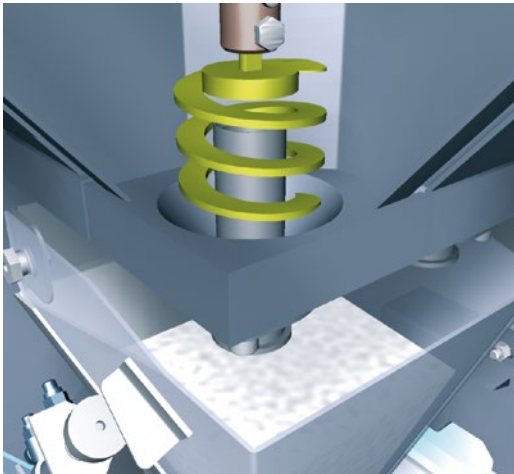

GRAVICOLOR 30 MD



motan's GRAVICOLOR units dose and mix up to four materials precisely and with maximum accuracy of blend. These modular gravimetric units are designed for injection moulding, blow moulding and extrusion.

Even with large throughputs, IntelliBlend ensures an excellent recipe accuracy.

The GRAVICOLOR series forms part of the total motan range of products and systems for all stages of the management, conditioning and preparation of plastic granules. Build quality, plus the engineering and service standards which motan applies to all parts of its operation, ensure high performance and reliable operation.

Dosing

Except for the additive micro dosing on the GRAVICOLOR 30 MD, all component materials are dosed by the unique motan cone-dosing system. This dosing system ensures that a high total material throughput can be achieved, even when metering a large number of additives.

On the GRAVICOLOR 30 MD, additives or masterbatch are dosed by an innovative and highly accurate micro dosing unit. The additive is dosed into the weigh bin using a vertically aligned feed-screw.

GRAVICOLOR

GRAVICOLOR 60



GRAVICOLOR 100



Weigh bin with mixing chamber



Supply hopper

The stainless steel supply hoppers are of modular design; some can be removed and all are easily accessible for cleaning. The design features provide optimum flexibility for processing different materials.

Conveying

All GRAVICOLOR units can optionally be equipped with an integrated conveying control which allows the control of up to seven material loaders with a blower station; i.e. material handling for a 4-component mixing station with processing machine can, for example, be controlled and operated directly via the GRAVICOLOR.

For the installation of complex systems there is the possibility of networking several GRAVICOLOR units with each other or with other motan controls of the CONTROLnet family. This guarantees a high degree of flexibility.

Installation

GRAVICOLOR units can either be mounted directly onto the feed throat of the processing machine or operated as a central mixing station. In the latter case, the unit is set up on a support frame with material hopper and suction box (optional).

Monitoring

Large sight glasses in the hoppers and the front door of the units allow visual control of the entire dosing and mixing process.

Mixing chamber

The specially developed mixing chamber and differently adjustable mixing intervals guarantee safe homogenisation of the material mix.

GRAVICOLOR 30 MD with removable supply hopper

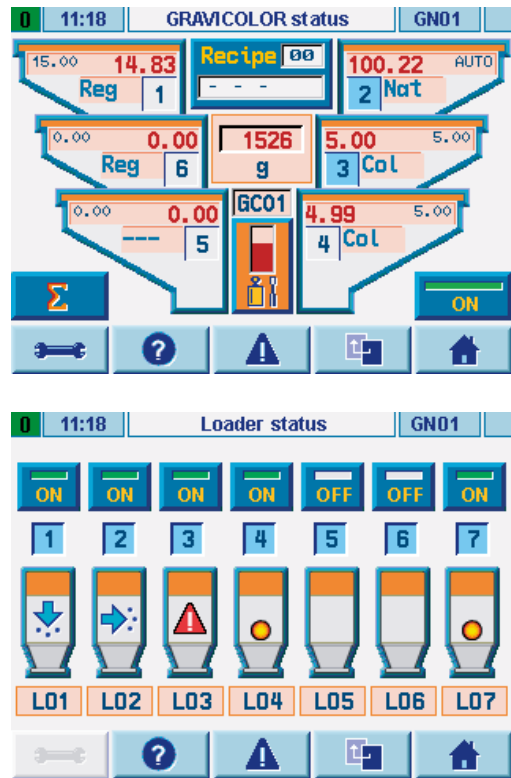
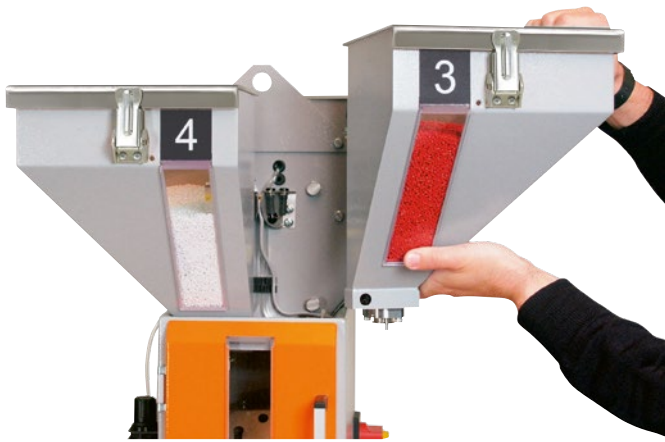

Cleaning and material changes

Fast material changes require easy access to all parts in contact with the material to ensure efficient cleaning. Hinged lids and large, removable sight glasses or removable supply hoppers enable complete and thorough cleaning of the hoppers.

The large front door, the removable weigh bin and the easily accessible mixing chamber simplify cleaning at material change.

All GRAVICOLOR parts in contact with material are made of stainless steel, preventing contamination of the granulate.

GRAVireport (optional)

With this PC program, process data of up to 252 GRAVICOLOR units can be captured and evaluated via Ethernet.

GRAVinet control

The operating unit can either be mounted on the GRAVICOLOR or operated remotely. In addition, integrated Ethernet technology enables operation via a motan WEBpanel or a PC from any location.

Further characteristics are:

- Colour graphic display with touch screen
- Simple intuitive handling via standardised user interface
- Powerful and accurate process control with IntelliBlend, continuous self-optimisation and sophisticated vibration management
- Detailed report and print functions via network or serial interfaces
- Integrated network interface (Ethernet) as well as Internet technology
- Integrated convey control (optional)
- Recipe management
- Possibility to set up coupled line systems (optional)
- LINKnet interface for visualisation (optional)

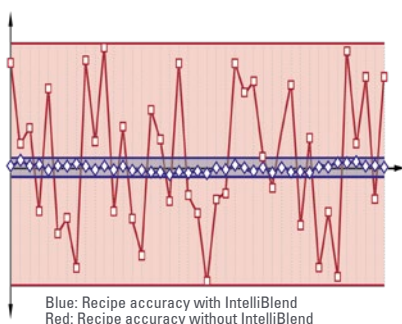

Recipe accuracy through IntelliBlend

Independent of recipes, materials or the operational environment, IntelliBlend analyses all process data achieving the best possible operating point at any time through continuous self-optimisation. Recipe integrity results in an excellent and consistent product quality.

GRAVICOLOR

TECHNICAL DATA

GRAVICOLOR 30 MD

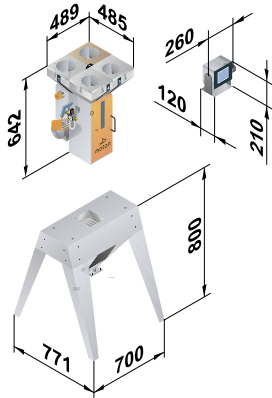

GRAVICOLOR 60

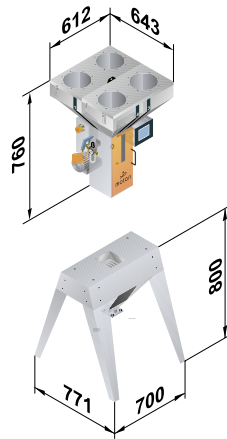

GRAVICOLOR 100

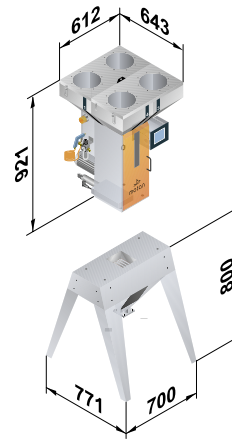

All dimensions in mm

Technical data			
Dosing and mixing unit Type GRAVICOLOR	30 MD	60	100
Number of dosing modules	4	4	4
Average throughput (kg/h)	60	90	150
Dosing ratio per main material %	5 - 100	5 - 100	5 - 100
Dosing ratio per additive %	0.1 - 10	0.5 - 10	0.3 - 10
Volume of supply hopper main material (l)	7	18	18
Volume of supply hopper additive (l)	7	18	18
Power supply (V/Hz)	1/N/PE 230/50	1/N/PE 230/50	1/N/PE 230/50
Connected load (W)	100	100	300
Compressed air oil and water-free (bar)	6 - 8	6 - 8	6 - 8
Weight without support frame approx. (kg)	60	70	80
Colour RAL (orange/grey)	2011/7040	2011/7040	2011/7040

Subject to technical changes

YOUR BENEFITS

- Documented production process (report and print function via Ethernet or serial interface)
- Simple operation through colour graphic display with touch screen – no programming necessary
- Recipe management
- Integrated network connection (Ethernet) as standard

Cost savings through

- guaranteeing recipe integrity and lowest possible additive consumption using IntelliBlend
- high productivity and consistent product quality
- low space requirement
- fast and easy material change
- regrind management to prevent overdosing of other components
- versatile operation (central mixing unit or machine mounted unit)
- integrated conveying control (option)

Production reliability through

- continuous self-optimisation by set/actual comparison
- maximum repeatability and extraordinary recipe accuracy through IntelliBlend

To find your local partner, please visit our website.

