

DOSING AND MIXING

GRAVICOLOR

Gravimetric dosing and mixing units



ZERO LOSS

GRAVICOLOR

GRAVIMETRIC DOSING AND MIXING UNITS

GRAVICOLOR 30 MD



GRAVICOLOR 100



GRAVICOLOR 300/600



GRAVICOLOR 60



GRAVICOLOR

motan's GRAVICOLOR units dose and mix up to six materials precisely and with maximum accuracy of blend. These modular gravimetric units are designed for injection, blow moulding and extrusion and provide throughputs up to 2200 kg/h.

Independent of recipes, materials or the operational environment, IntelliBlend analyses all process data achieving the best possible operating point at any time through continuous self-optimisation. Recipe integrity results in an excellent and consistent product quality.

The GRAVICOLOR series forms part of the total motan range of products and systems for all stages of the management, conditioning and preparation of plastic granules. The design quality, plus the engineering and service standards which motan applies to all parts of its operation, ensure high performance and reliable operation.

Installation

GRAVICOLOR units can either be mounted directly onto the feed throat of the processing machine or operated as a central mixing station. In the latter case, the unit is set up on a support frame with material hopper and suction box (optional).

Mixing chamber

The specially developed mixing chamber and differently adjustable mixing intervals guarantee correct homogenisation of the material mix.

Conveying

All GRAVICOLOR units can be optionally equipped with an integrated conveying control which allows the control of up to seven material loaders with a blower station; i.e. material handling for a 6-component mixing station with processing machine can, for example, be controlled and operated directly via the GRAVICOLOR.

For the installation of complex systems, there is the possibility of networking several GRAVICOLOR units with each other or with other motan controls of the CONTROLnet family. This guarantees a high degree of flexibility.

GRAVICOLOR 30 MD with removable supply hopper

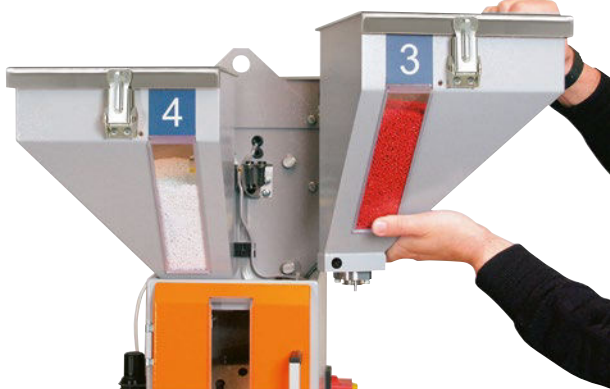

Weigh bin and mixing chamber



Cleaning and material changes

Fast material changes require easy access to all parts in contact with the material to ensure efficient cleaning. Hinged lids and large removable sight glasses or removable supply hoppers enable complete and thorough cleaning of the hoppers.

The large front door, the removable weigh bin and the easily accessible mixing chamber simplify cleaning at material change.

All GRAVICOLOR parts in contact with material are made of stainless steel, preventing contamination of the granulate.

GRAVireport (optional)

With this PC program process data of up to 252 GRAVICOLOR units can be captured and evaluated via Ethernet.

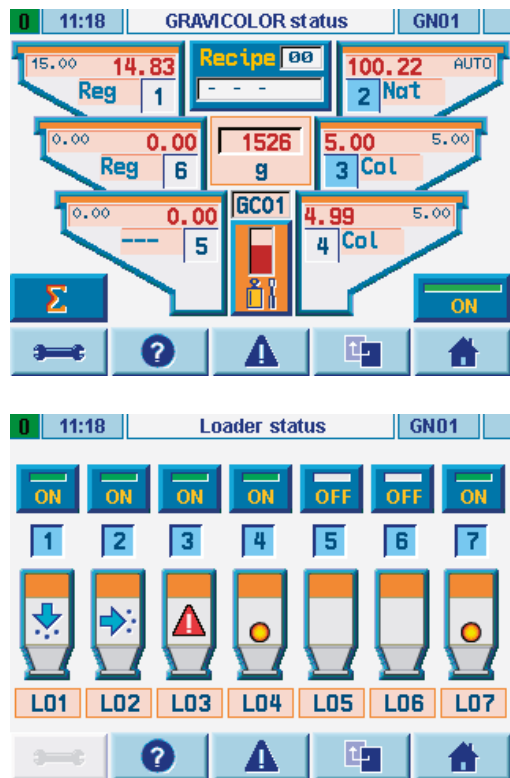

GRAVInet control

The operating unit can either be mounted on the GRAVICOLOR or operated remotely. In addition, integrated Ethernet technology enables operation via a motan WEBpanel or a PC from any location.

Further characteristics are:

- Colour graphic display with touch-screen
- Simple intuitive handling via standardised user interface
- Powerful and accurate process control with IntelliBlend, continuous self-optimisation and sophisticated vibration management
- Detailed report and print functions via network or serial interfaces
- Integrated network interface (Ethernet) as well as Internet technology
- Integrated convey control (optional)
- Recipe management
- Possibility to set up coupled line systems (optional)
- LINKnet interface for visualisation (optional)

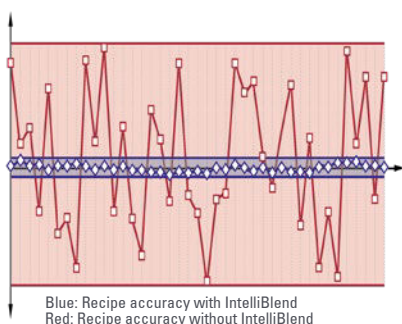

Recipe accuracy through IntelliBlend

Independent of recipes, materials or the operational environment, IntelliBlend analyses all process data achieving the best possible operating point at any time through continuous self-optimisation. Recipe integrity results in an excellent and consistent product quality.

GRAVICOLOR

TECHNICAL DATA

GRAVICOLOR 30 MD

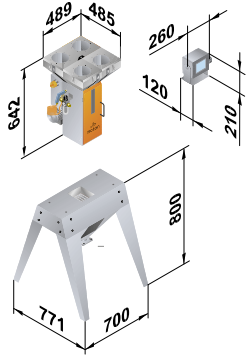

GRAVICOLOR 60

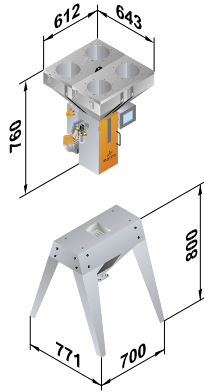

GRAVICOLOR 100

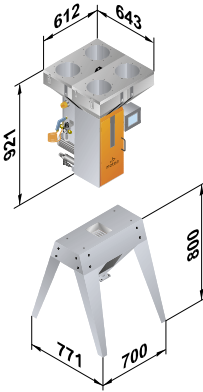

GRAVICOLOR 300/600

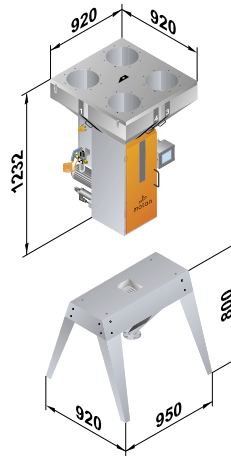

GRAVICOLOR 1000

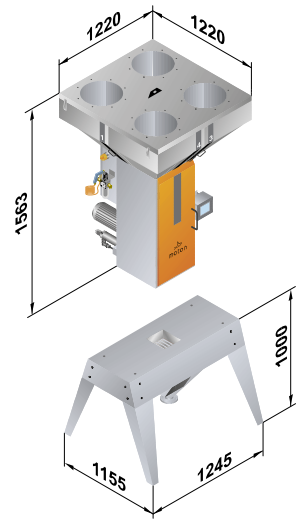

All dimensions in mm

Technical data						
Dosing and mixing unit	30 MD	60	100	300	600 (R)	1000
Type GRAVICOLOR						
Number of dosing modules	4	4	4	4 - 6	4 - 6	4 - 6
Average throughput (kg/h)	60	90	150	300	600	1000
Dosing ratio per main material %	5 - 100	5 - 100	5 - 100	5 - 100	5 - 100	5 - 100
Dosing ratio per additive %	0.1 - 10	0.5 - 10	0.3 - 10	0.3 - 10	0.3 - 10	0.3 - 10
Volume of supply hopper main material (l)	7	18	18	60	60	120
Volume of supply hopper additive (l)	7	18	18	30	60	60
Power supply (V/Hz)	1/N/PE 230/50	1/N/PE 230/50	1/N/PE 230/50	1/N/PE 230/50	1/N/PE 230/50	1/N/PE 230/50
Connected load (W)	100	100	300	400	400	400
Compressed air oil and water-free (bar)	6 - 8	6 - 8	6 - 8	6 - 8	6 - 8	6 - 8
Weight without support frame approx. (kg)	60	70	80	200	200	315
Colour RAL (orange/grey)	2011/7040	2011/7040	2011/7040	2011/7040	2011/7040	2011/7040

Subject to technical changes

YOUR BENEFITS

Cost savings through

- guaranteeing recipe integrity and lowest possible additive consumption using IntelliBlend
- high productivity and consistent product quality
- small space requirement
- fast and easy cleaning
- fast and easy material change
- regrind management, preventing an overdose of other components

- flexible operation (central mixing unit or machine mounted unit)
- integrated conveying control (option)

Production reliability through

- documented production process (report and print function via Ethernet or serial interface)
- simple operation – no programming necessary

- continuous self-optimisation by set/actual comparison
- regrind management
- integrated network connection (Ethernet) as standard
- maximum repeatability and extraordinary recipe accuracy through IntelliBlend

To find your local partner, please visit our website.

